

Original BMW Accessories.

Installation Instructions.



M Performance Accent Strips Film Retrofit Kit.

BMW X3 (G45)
BMW X4 (F26)
BMW X6 (F16)
BMW 1 Series 5-door (F20)
BMW 1 Series 3-door (F21)
BMW 2 Series Coupé (F22)
BMW 2 Series Convertible (F23)
BMW 3 Series Saloon (F30)
BMW 3 Series Touring (F31)
BMW 4 Series Gran Coupé (F36)
BMW 5 Series Saloon (G30, G60)
BMW 5 Series Touring (G31, G61)
BMW 5 Series Saloon Long Version (G38, G68)
BMW M5 Saloon (G90)
BMW M5 Touring (G99)

Retrofit kit number

51 14 2357133	Accent strips film left/right (F26)
51 14 2357137	Accent strips film left/right (F16)
51 14 2365552	Accent strips film left/right (F20)
51 14 2406145	Accent strips film left/right (F21, F22, F23)
51 14 2365577	Accent strips film left/right (F30, F31)
51 14 2406751	Accent strips film left/right (F36)
51 14 2432164	Accent strips film left/right (G30, G31)
51 14 2444264	Accent strips film left/right (G38)
82 14 5A8EDB7	Frozen Black accent strips film left/right (G60, G61)
82 14 5B3C732	Frozen Black accent strips film left/right (G68)
82 14 5B4CB34	Accent strips film left/right (G90, G99)
82 14 5B3E1E0	Accent strips film left/right (G45)

Installation time

The installation time is **approx. 1.0 hour**. This may vary depending on the condition of the car and its equipment package.

The installation time shown does not include any time spent on programming/coding.

The calculation of the total costs for the programming time must be factored into the calculation of retrofitting costs (must not be invoiced under the warranty).

Important information

These installation instructions are primarily designed for use within the BMW dealership organisation and by authorised BMW service companies.

These installation instructions are intended for use by qualified specialist staff trained on BMW cars with the relevant expert knowledge.

All work must be completed using the latest BMW repair manuals, wiring diagrams, servicing manuals and work instructions, in a logical order, using the prescribed tools (special tools), and observing current health and safety regulations.

If you experience installation or functional problems, restrict troubleshooting to approx. 0.5 hours for mechanical work and 1.0 hour for electrical work.

To avoid unnecessary extra work and/or costs, send an inquiry to the technical parts support team.

Quote the following information:

- VIN,
- retrofit kit part number,
- a detailed description of the problem,
- any work already carried out.

Do not archive the printout of these installation instructions. The current version can be found in the EPC.

Pictograms

- ⚠ Denotes instructions that draw your attention to dangers.
- ▶ Denotes instructions that draw your attention to special features.
- ◀ Denotes the end of the instruction or other text.

Installation information

All illustrations show LHD cars; proceed in the same way on RHD cars. Installation is shown on one side of the car only, proceed in the same way on the other side. Installation is shown on the **F26**; the same installation procedures apply to the other cars.

Parts kit designation for all cars except F26: Accent strips **B** and **C** are grouped together on a backing film to form **BC**, and **D** and **E** to form **DE**. Installation is however in the same sequence, in the same manner as on all other cars.

Different installation process for the F22/F23: Right tail accent strip **GHI** must be cut at the contour of the tank cover using a suitable tool.

The bonding surfaces must be cleaned with a cleaner and must be dry, clean and free from wax or grease. The ambient temperature for bonding and drying must not be below 15 °C or exceed 35 °C.

The film adjusts to the surface of the car under the influence of heat (direct sunlight, hair dryer); if required this can be used to get rid of air bubbles trapped underneath it.

The following processing instructions apply to the retrofit kit:

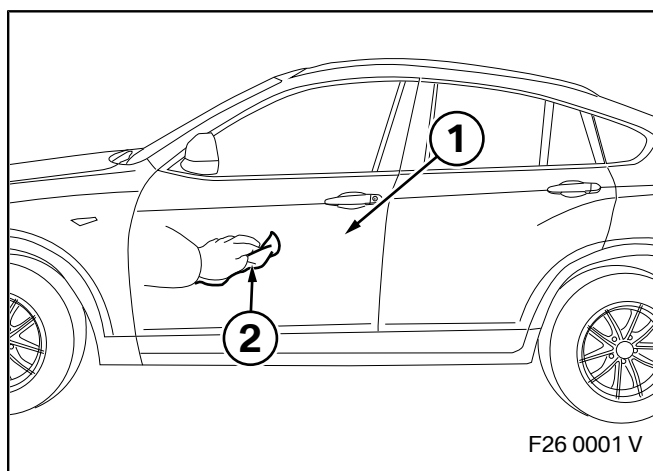

- ▶ The areas being bonded must be completely dry, clean and free from wax or grease. ◀

The bonding surfaces (1) must be cleaned with a cleaning cloth (2) and suitable cleaning products.

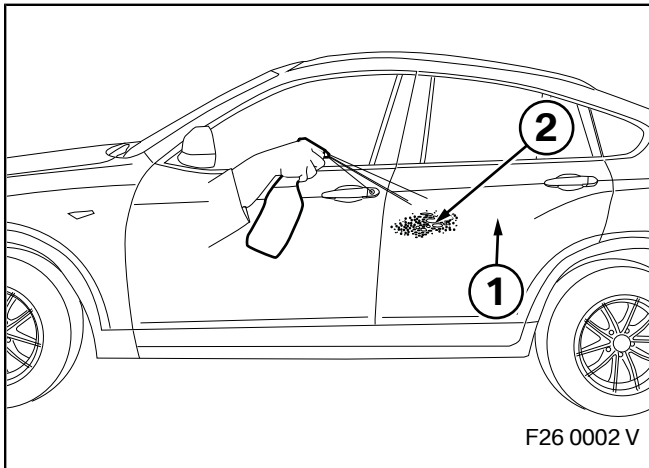

Fill the spray bottle (included in installation kit 51 91 2 410 645) with water, adding a little washing-up liquid as required.

The surfaces of the car (1) must be sprayed thoroughly and generously with the installation solution (2).

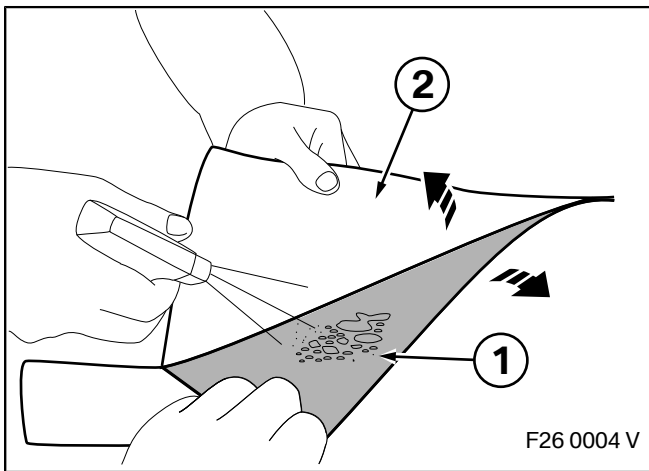

▶ The adhesive side of the stickers (1) is covered with a printed backing film (2). ◀

Carefully remove the protective film (2) at an angle of 180° from the stickers (1).

As you do so, thoroughly wet the adhesive side with installation solution.

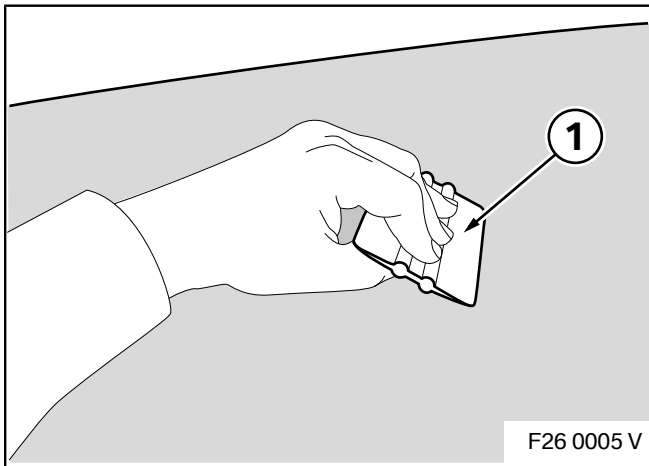

▶ Do not apply excessive pressure to the surfaces of the car with the blade (1), otherwise you may inadvertently cause damage. ◀

After running the blade over the foil application, wait for approx. 10 minutes and then carefully pull the application tape off the foil application at an angle of 180°, wetting the application tape liberally with installation solution if necessary.

Press any projecting edges down with the blade (1).

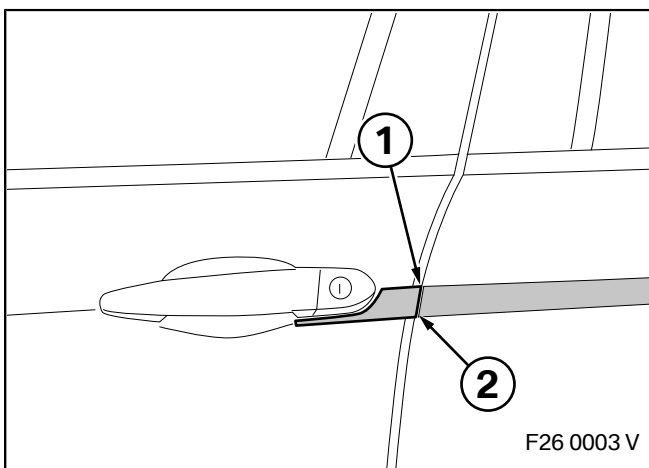

Foil application sections with edges abutting the door openings are to be positioned in such a way that the end edges (1) touch the opposite edge of the gap (2). The foil application sections are then to be pressed around the edge and smoothed down with the blade.

Special tools required

Installation kit (Part No. 51 91 2 410 645)

Advice to be given to the customer

- The car may be driven after 6 hours and taken through a car wash after 72 hours.
- When using high pressure steam cleaners the following restrictions must be observed:
 - Maintain minimum distance between cleaning nozzle and bodywork: 1 m
 - Maximum temperature: 60 °C
 - The cleaning jet should not be angled at more than 30° from perpendicular to the bodywork
- The film should be thoroughly cleaned on a regular basis (every 8-10 weeks).
- Particularly aggressive contaminants such as tree resin, dead insects or bird droppings, should be washed off as soon as possible with warm soapy water.
- Matt films must not be polished to a shine. In addition, hot wax must not be used.

Table of contents

Section	Page
1. Accent strips parts list	6
2. Accent strips parts list for G60, G61, G68	7
3. Accent strips parts list for G90, G99	8
4. Accent strips parts list G45	9
5. Preparatory work	10
6. Installing the accent strips	11
7. Installing the accent strips for G60, G61, G68	13
8. Installing the accent strips for G90, G99	15
9. Installing the G45 accent strips	16
10. Concluding work and coding	17

1. Accent strips parts list

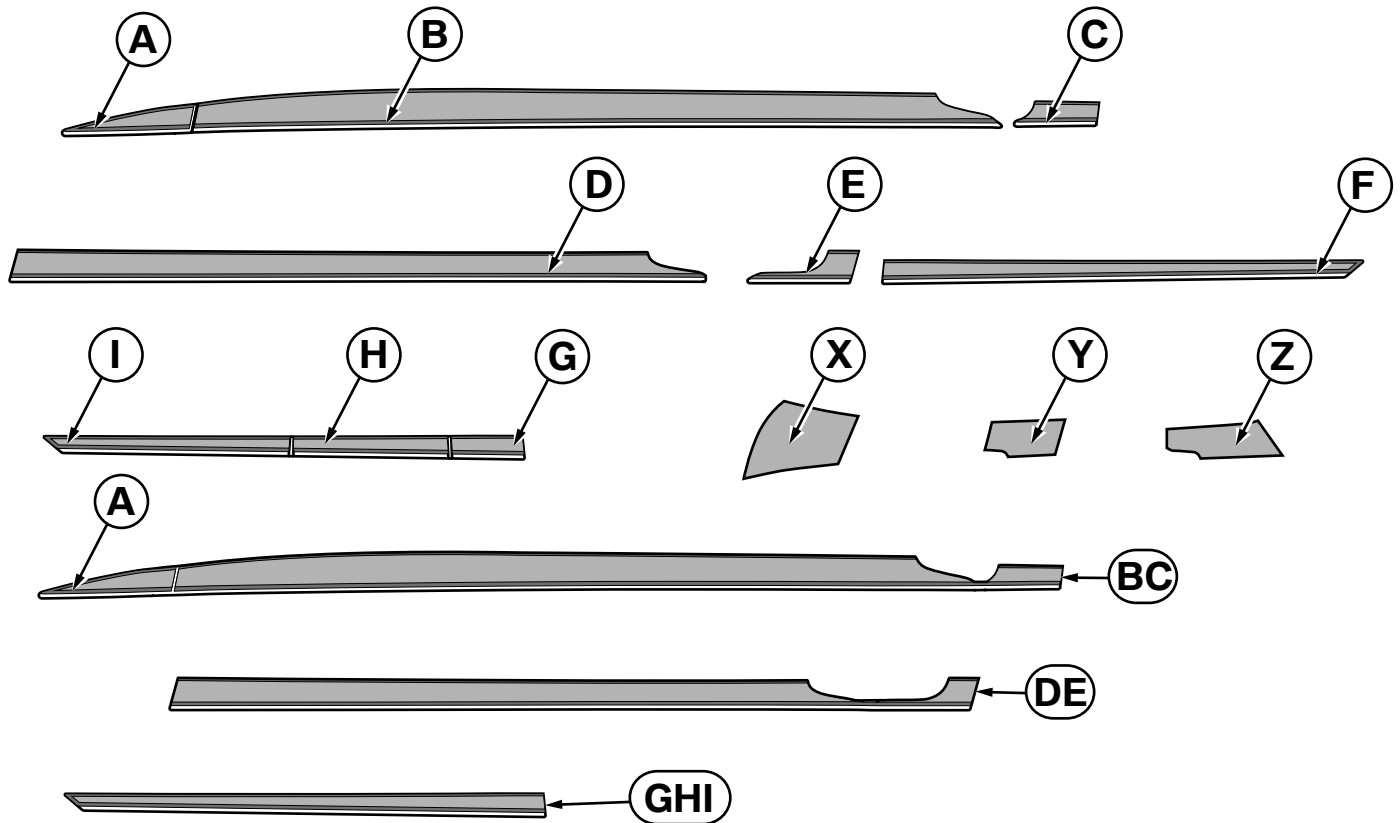

F26 0017 V

Legend

- A** Front left / right accent strip
- B** Front left / right door accent strips **(F26 only)**
- C** Front left / right door short accent strips **(F26 only)**
- D** Rear left / right door accent strips **(F26 only)**
- E** Rear left / right door short accent strips **(F26 only)**
- F** Left tail accent strip
- G** Front right tail accent strip
- H** Right tail fuel filler cap accent strip
- I** Rear right tail accent strip
- X** Front left / right template
- Y** Centre left / right template
- Z** Rear left / right template
- BC** Front left / right door accent strips **(all cars except F26)**
- DE** Rear left / right door accent strips **(all cars except F26)**
- GHI** Right tail accent strips **(only for F22/F23 cars)**

2. Accent strips parts list for G60, G61, G68

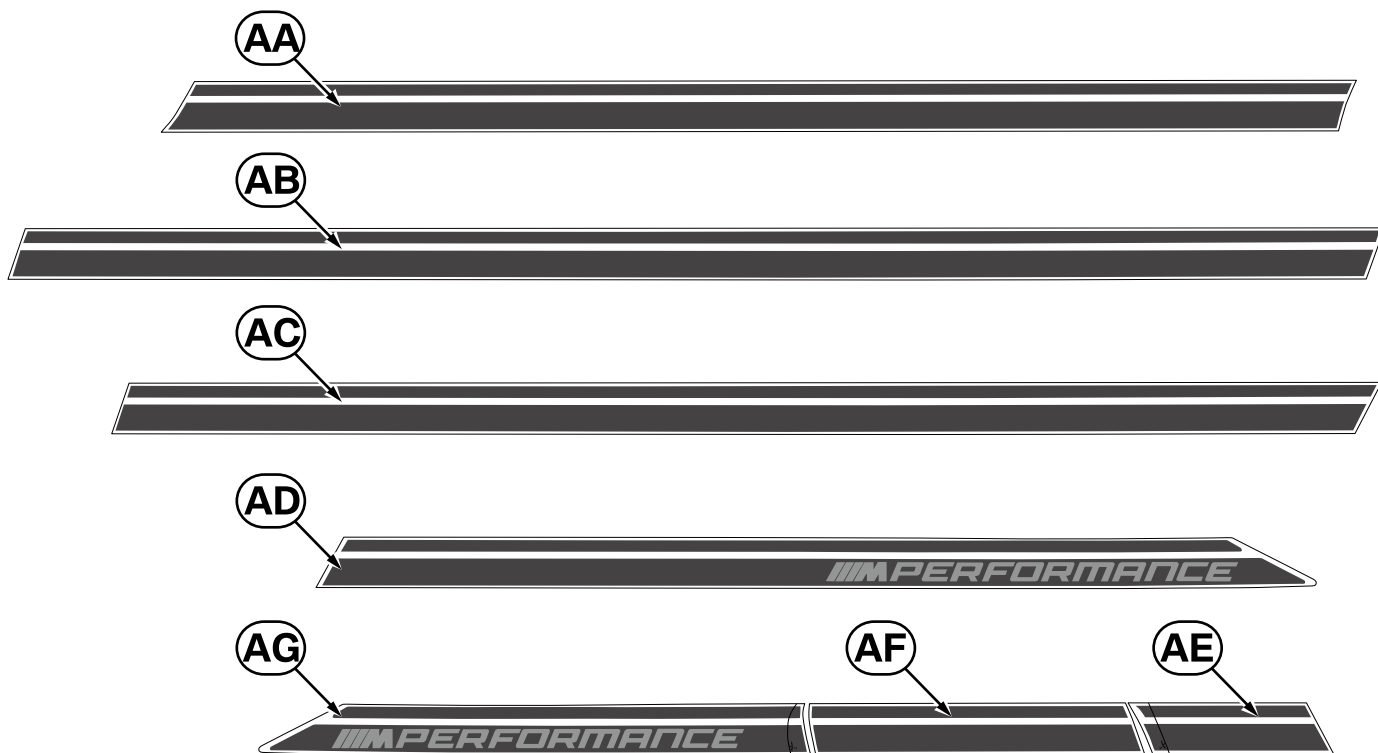

G60 0100 V

Legend

- AA** Front left/right accentuation stripe (left shown in figure)
- AB** Front left/right door accentuation stripe (left shown in figure)
- AC** Rear left/right door accentuation stripe (left shown in figure)
- AD** Rear left accentuation stripe
- AE** Rear left accentuation stripe
- AF** Rear right fuel filler cap accentuation stripe
- AG** Rear right finishing accentuation stripe

3. Accent strips parts list for G90, G99

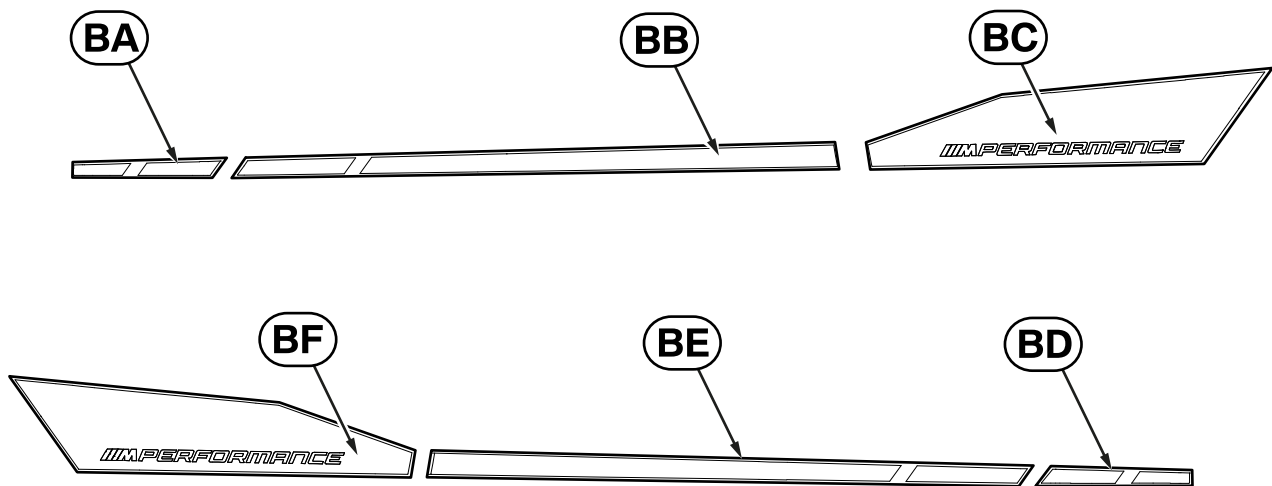

G90 0110 V

Legend

- BA** Front left accent strip
- BB** Front left door accent strip
- BC** Rear left door accent strip
- BD** Front right accent strip
- BE** Front right door accent strip
- BF** Rear right door accent strip

4. Accent strips parts list G45

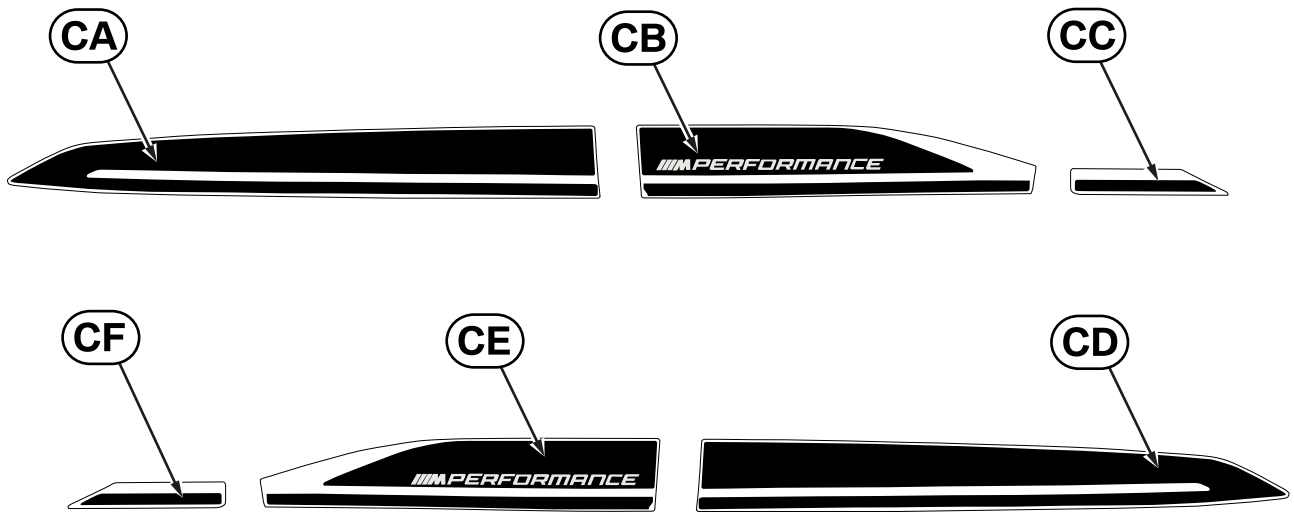

G45 0040 V

Legend

- CA** Front left door accent strip
- CB** Rear left door accent strip
- CC** Rear left accent strip
- CD** Front right door accent strip
- CE** Rear right door accent strip
- CF** Rear right accent strip

5. Preparatory work

	ISTA No.
None	---

6. Installing the accent strips

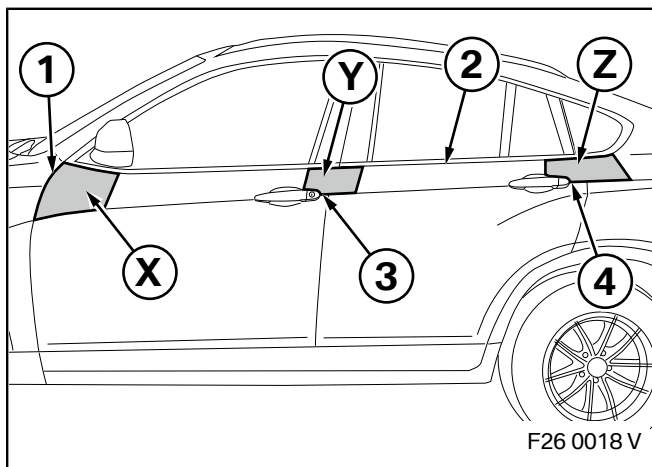

Place front template **X** on the door contour (1), align it and secure it.

Place centre template **Y** on the visible finisher (2) and door handle contour (3), align it and secure it.

Place rear template **Z** on the visible finisher (2) and door handle contour (4), align it and secure it.

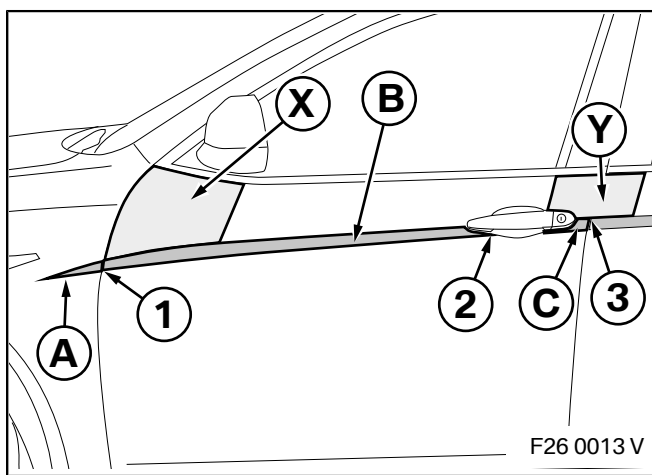

For F26 cars

Position front accent strip **A** and front door accent strip **B** on front template **X** and the door edge (1), as well as the door handle contour (2), align it, press it on and run the blade over it.

Position short front door accent strip **C** on centre template **Y** and the door edge (3), align it, press it on and run the blade over it.

For all cars except F26/F22/F23

Position front accent strip **A** and front door accent strip **BC** on front template **X** and centre template **Y**, as well as the door edge (1), door handle contour (2) and door edge (3), align it, press it on and run the blade over it.

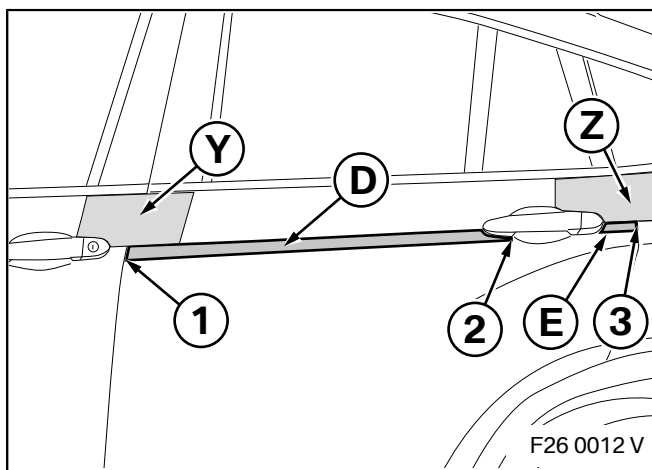

For F26 cars

Position rear door accent strip **D** and rear door short accent strip **E** on centre template **Y** and rear template **Z**, as well as the door edge (1), door handle contour (2) and door edge (3), align it, press it on and run the blade over it.

For all cars except F26/F22/F23

Position rear door accent strip **DE** on centre template **Y** and rear template **Z**, as well as the door edge (1), door handle contour (2) and door edge (3), align it, press it on and run the blade over it.

6. Installing the accent strips

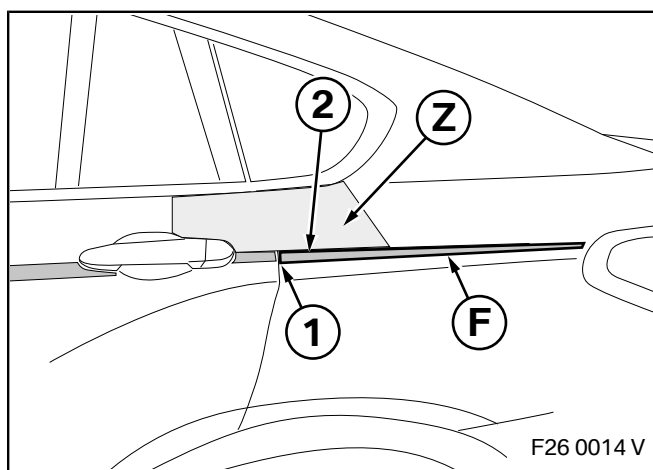

For all cars

Place left tail accent strip **F** on the door edge (1) and edge (2) of rear template **Z**, align it, press it into position and run the blade over it.

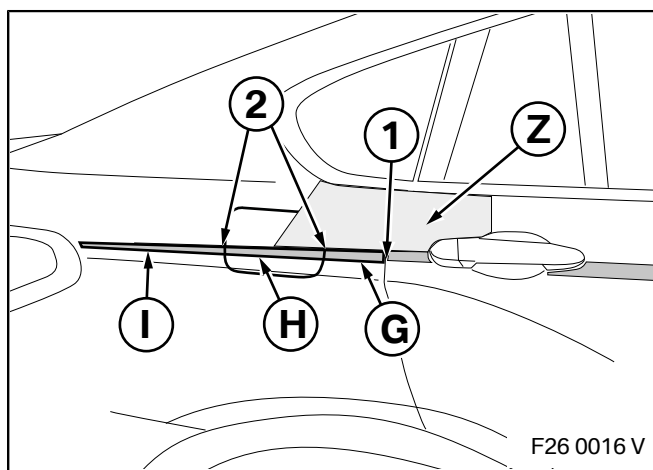

For all cars except F22/F23

Position rear rear accent strip **I**, rear fuel filler cap accent strip **H** and front rear accent strip **G** on rear template **Z** and on the door edge (1) and fuel filler cap edges (2), align it, press it on and run the blade over it.

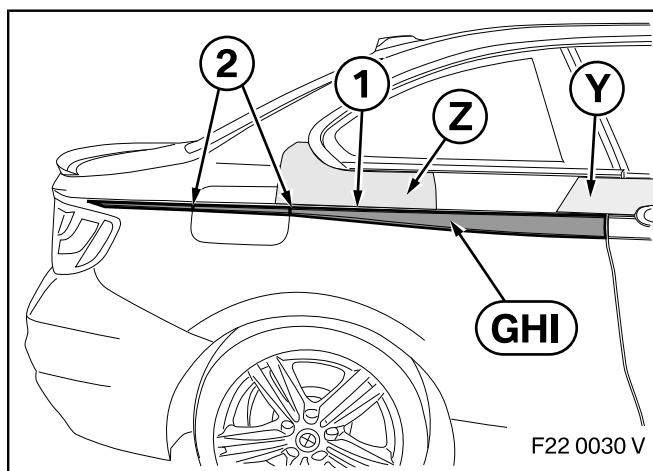

For F22/F23 cars

Place right tail accent strip **GHI** on rear template **Z**, centre template **Y** and on the edge (1), align it, press it into position and run the blade over it. Cut right tail accent strip **GHI** at the tank cover edges (2) using a suitable tool, press around the edge and run the blade over it.

7. Installing the accent strips for G60, G61, G68

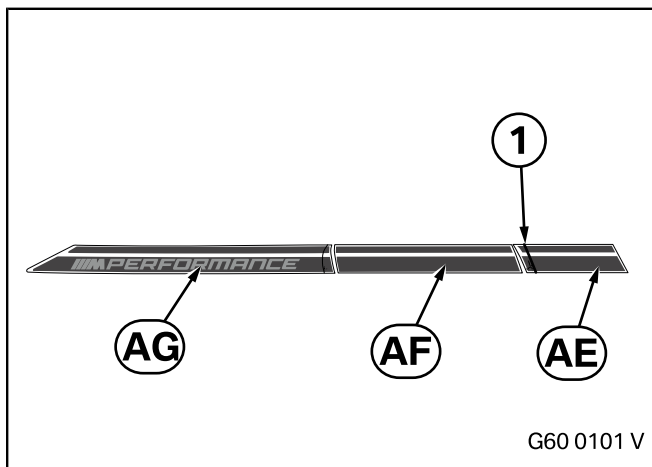

For G60/G68 cars

For G60/G68 cars, the rear right accent strip **AE** must be cut at the marked cutting edge (1).

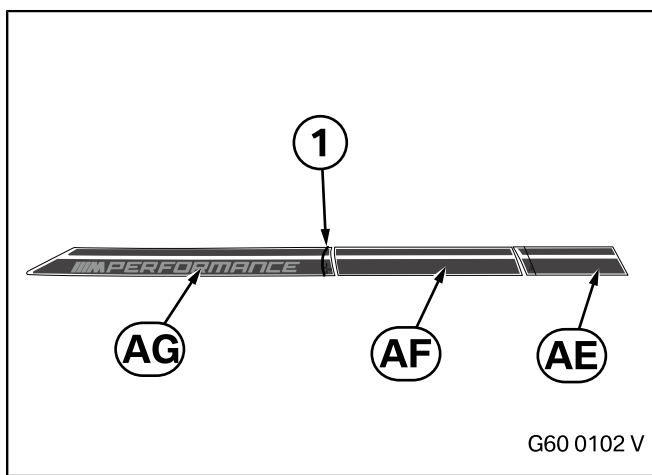

For G61 cars

For G61 cars, the rear right finishing accentuation stripe **AG** must be cut at the marked cutting edge (1).

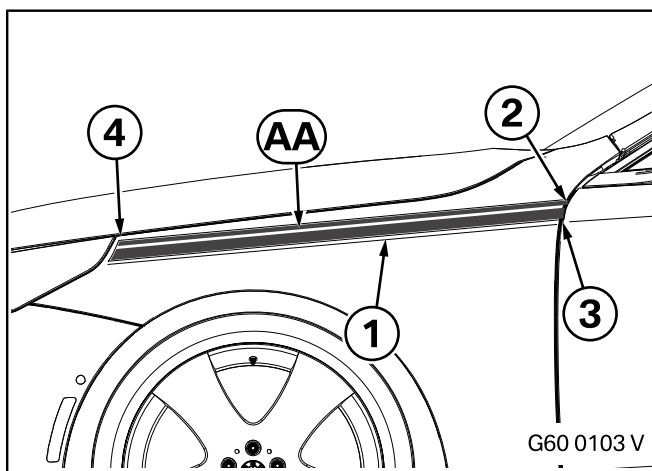

For all cars

Align the front left/right accentuation stripe **AA** along the refractory edge (1) and at the same time keep the edge (2) of the front left/right accentuation stripe **AA** flush with the edge (3) of the front door. Align the front left/right accentuation stripe **AA** towards the headlight (4), press it into position and smooth it with the blade.

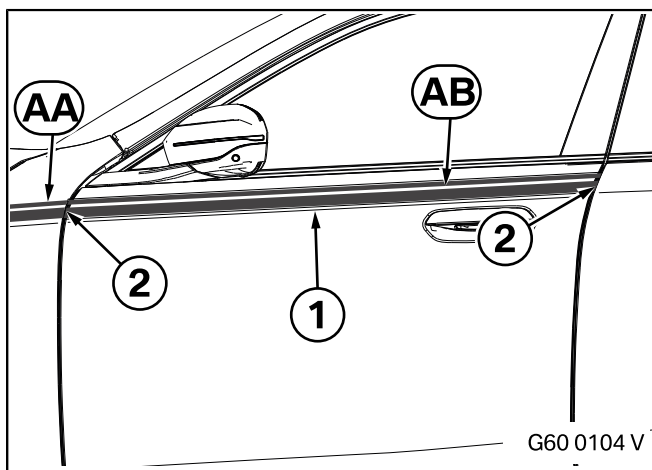

Ensure that the front left/right door accentuation stripe **AB** continues in line with the front left/right accentuation stripe **AA**. ◀

Align the front left/right door accentuation stripe **AB** along the refractory edge (1) and centre it between the two door edges (2), press it into place and smooth it with the blade.

7. Installing the accent strips for G60, G61, G68

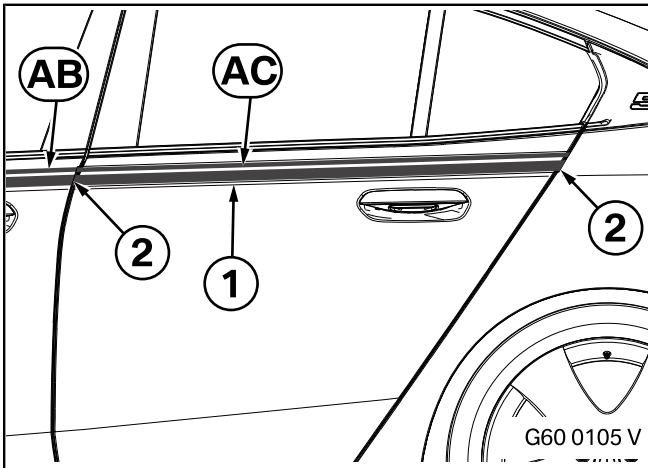

- Ensure that the rear left/right door accentuation stripe **AC** continues in line with the front left/right door accentuation stripe **AB**. ◀

Align the rear left/right door accentuation stripe **AC** along the refractory edge (1) and centre it between the two door edges (2), press it into place and smooth it with the blade.

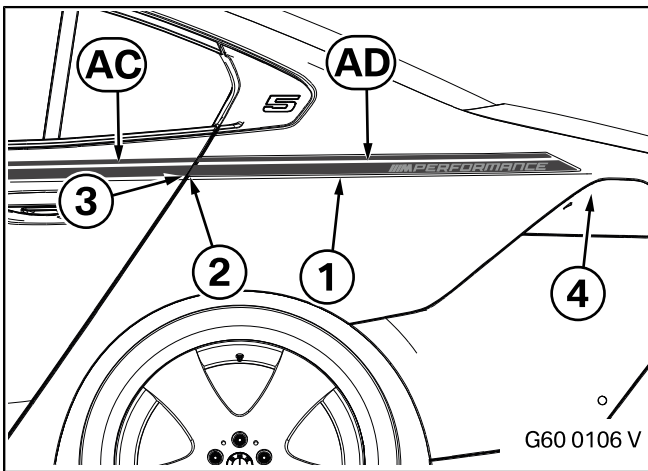

For the left-hand side of the car only

- Ensure that the rear left accentuation stripe **AD** continues in line with the rear door accentuation stripe **AC**. ◀

Align the rear left accentuation stripe **AD** along the refractory edge (1) whilst at the same time keeping the edge (2) of the rear left accentuation stripe **AD** flush with the edge (3) of the rear door. Align the rear left accentuation stripe **AD** towards the tail light (4), press it into position and smooth it with the blade.

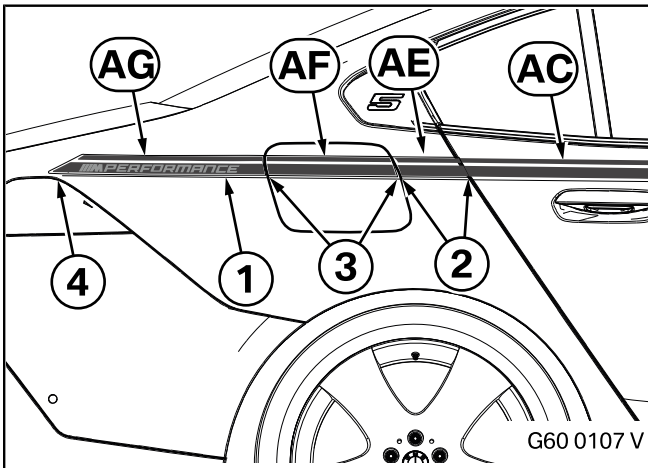

For the right-hand side of the car only

- Ensure that the rear right accentuation stripe **AE**, the rear right fuel filler cap accentuation stripe **AF** and the rear right finishing accentuation stripe **AG** form a straight line with the rear door accentuation stripe **AC**. ◀

Align the rear right door accentuation stripe **AE** along the refractory edge (1) and at the same time centre it between the two door edges (2), press it into place and smooth it with the blade.

Align the rear right fuel filler cap accentuation stripe **AF** along the refractory edge (1) and at the same time centre it between the two edges (3), press it into place and smooth it with the blade.

Align the rear right finishing accentuation stripe **AG** along the refractory edge (1) and at the same time position it flush with the edge (3) of the fuel filler cap, align it towards the tail light (4), press it into place and smooth it with the blade.

8. Installing the accent strips for G90, G99

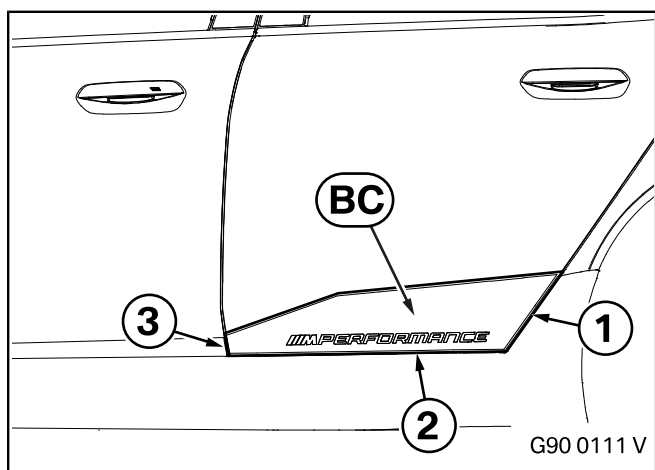

Position rear door accent strip **BC** on component edge (1) and align it with component edge (2). Rear door accent strip **BC** extends all the way to the opposite component edge (3). Then press it into place and run the blade over it.

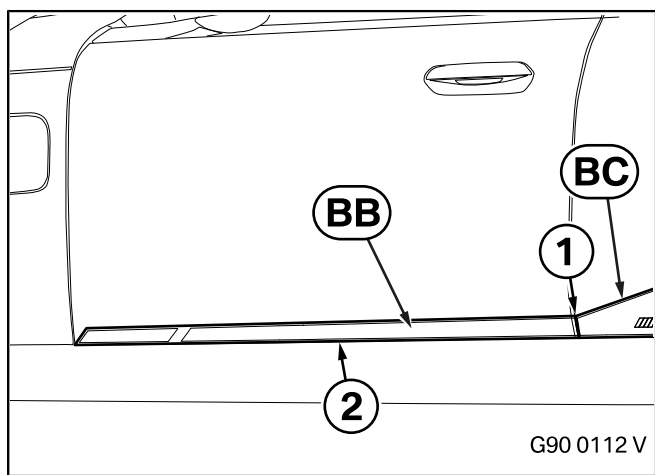

▶ Ensure that front door accent strip **BB** continues in line with rear door accent strip **BC**. ◀

Position front door accent strip **BB** on component edge (1) and align it with component edge (2). Then press it into place towards component edge (3) and run the blade over it.

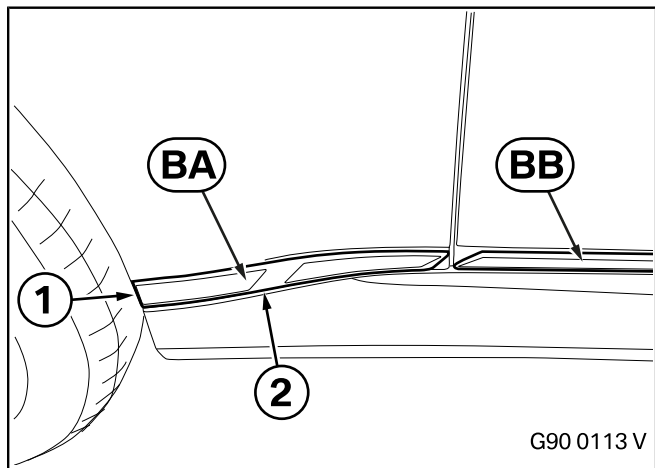

▶ Ensure that the front accent strip **BA** continues in line with the front door accent strip **BB**. This is of particular importance as component edge (2) is curved. ◀

Position front accent strip **BA** on component edge (1) and align it with component edge (2). Then press it into place and run the blade over it.

9. Installing the G45 accent strips

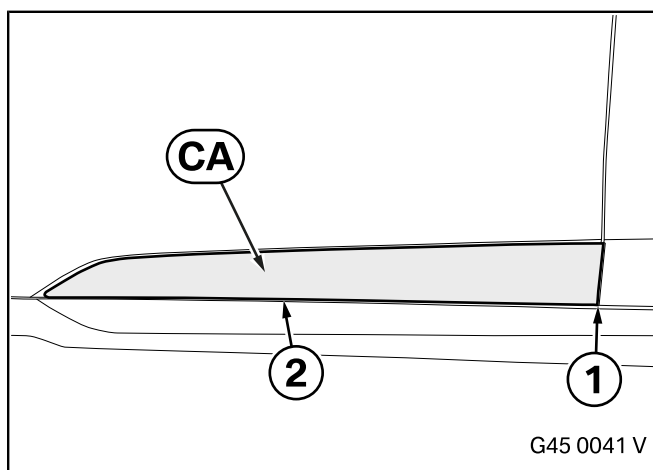

Position front left door accent strip **CA** on component edge (1) and align it with component edge (2). Then press it into place and run the blade over it.

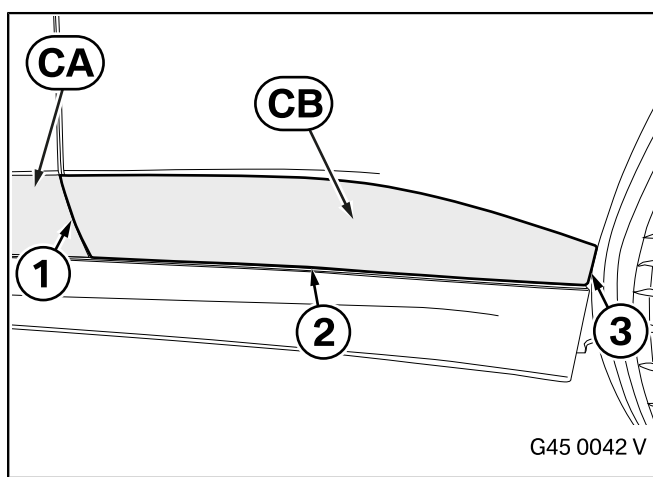

☐ Ensure that the front left door accent strip **CA** continues in line with rear left door accent strip **CB**. ◀

Position rear left door accent strip **CB** on the opposite component edge (1) and on component edge (2). Then align it towards component edge (3), press it into place and run the blade over it.

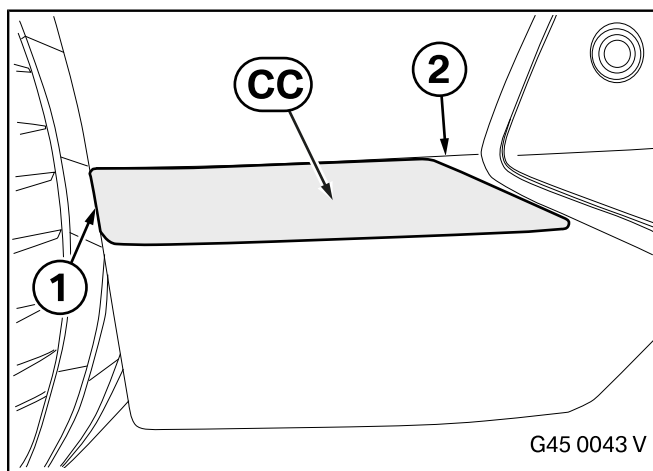

Position rear left accent strip **CC** on component edge (1) of the wheel arch and align it with the refractory edge (2). Then press it into place and run the blade over it.

10. Concluding work and coding

The retrofit system does not require programming / coding.

- Remove templates **X**, **Y** and **Z** from the car